

5602 with textile filter, internal filter shock and connection module



- ▶ Separates the carrying air from the conveyed product.
- ▶ The sealings fulfil the requirements of FDA.
- ▶ The filter bags are of food quality.
- ▶ Automatic filter cleaning.

Technical data

Description	Unit	Value
Feed pressure range	MPa	0.4–0.6
Material		ASTM 316L, Polyester
Temperature range	°C	0–60
Filter area	m ²	0.60
Min particle size	µm	5.0

Technical data, specific

Description	Unit	Value	
		0106820/1	0106820/2
Material		NBR, C	Q
Weight	kg	34.2	34.2

Ordering information

Description	Art. No.
Filter unit 5602 textile filter int tang, NBR	0106820/1
Filter unit 5602 textile filter int tang, Q	0106820/2

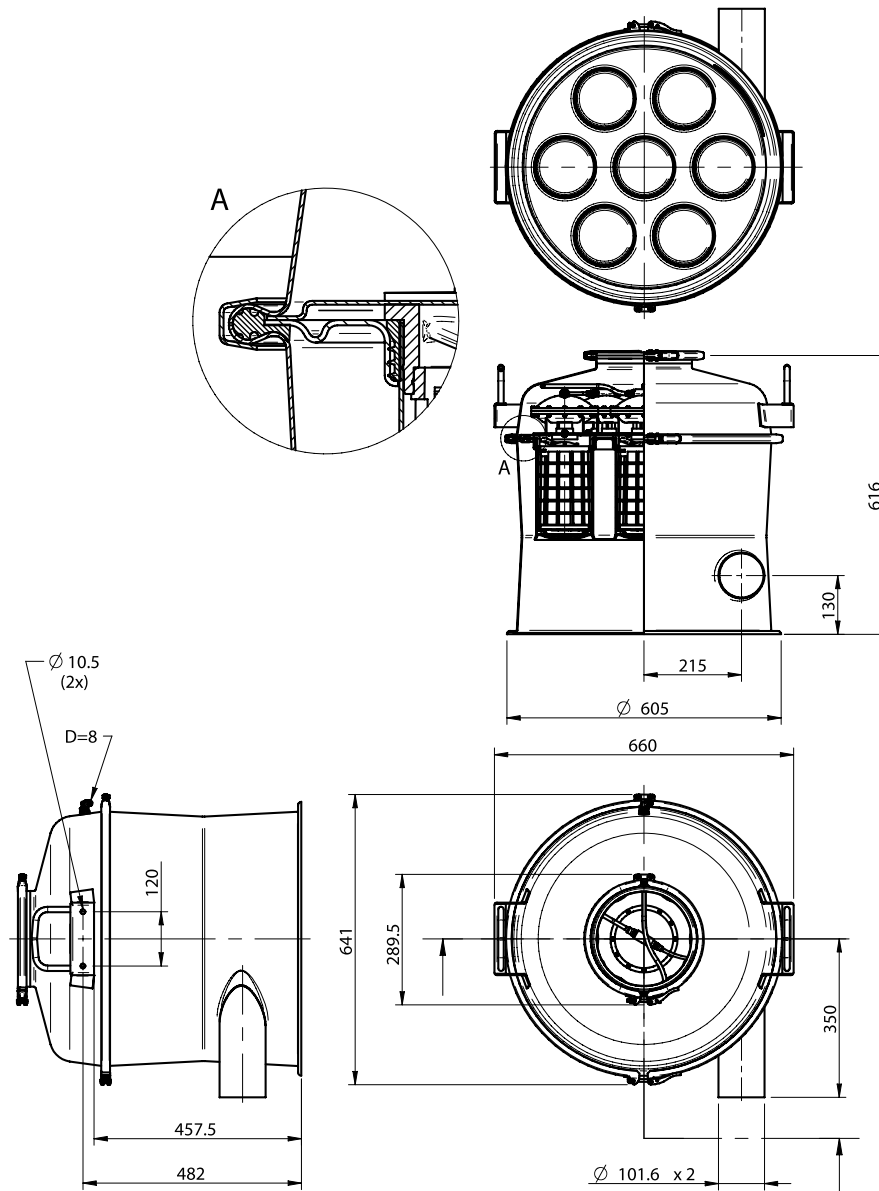

Filter units