

MAXI L600



- ▶ Power source of the vacuum conveyor.
- ▶ High vacuum flow.
- ▶ Short response time.
- ▶ Compact size and low weight in comparison to conventional mechanical pumps.
- ▶ Regulator kit is included.

Technical data

Description	Unit	Value
Feed pressure range	MPa	0.4–0.6
Air consumption range	NI/s	30–42
Vacuum range	-kPa	61–75
Noise level range	dBA	72–76
Material		Al, PPS, SS, NBR
Temperature range	°C	0–60
Weight	kg	13.3

Vacuum flow

Feed pressure MPa	Air consumption NI/s	Vacuum flow (NI/s) at different vacuum levels (-kPa)								Max vacuum -kPa
		0	10	20	30	40	50	60	70	
0.6	42	142.5	77.0	52.7	34.2	18.5	14.3	10.0	6.3	75
0.5	36	135.4	65.6	45.6	25.7	17.1	12.3	7.1	1.4	71
0.4	30	119.7	57.0	35.8	21.4	15.7	7.7	0.3	–	61

Evacuation time

Feed pressure MPa	Air consumption NI/s	Evacuation time (s/l) at different vacuum levels (-kPa)							Max vacuum -kPa
		10	20	30	40	50	60	70	
0.6	42	0.002	0.004	0.007	0.01	0.02	0.03	0.04	75
0.5	36	0.003	0.004	0.007	0.01	0.02	0.03	0.06	71
0.4	30	0.003	0.004	0.007	0.02	0.03	–	–	61

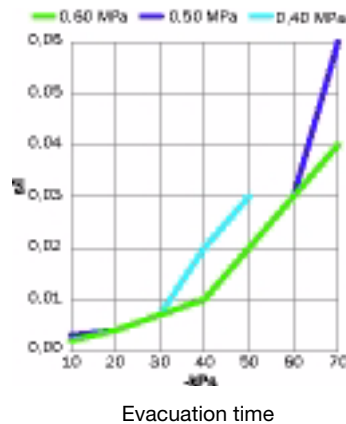
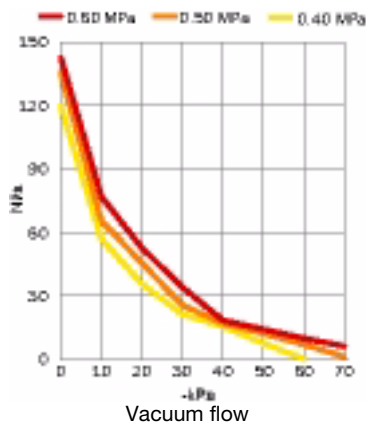

Ordering information

Description	Art. No.
Pump unit MAXI L600	0103880

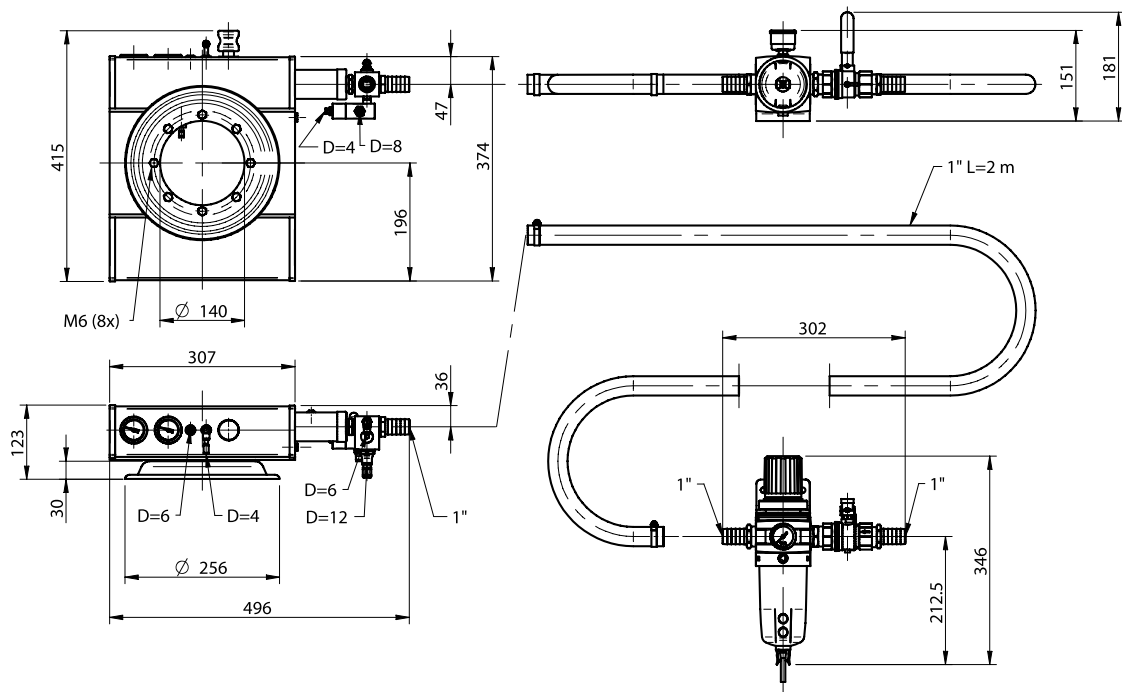

Ordering information accessories

Description	Art. No.
Central exhaust MLL600-800	3116018
Adapter MAXI L100-L1600 cpl	3102073